

OPERATION MANUAL



INDUSTRIAL PEDESTAL GRINDER

Model. BG-8

Order Code K8222

EDITION No : BG-8-1

DATE OF ISSUE : 08/2023

MACHINE DETAILS

MACHINE	Industrial Pedestal Grinder
MODEL NO.	BG-8
SERIAL NO.	
DATE OF MANF.	

DISTRIBUTED BY



www.machineryhouse.com.au

www.machineryhouse.co.nz

NOTE:

This manual is only for your reference. At the time of the compiling of this manual every effort to be exact with the instructions, specifications, drawings, and photographs of the machine was taken. Owing to the continuous improvement of the HAFCO METALMASTER machine, changes may be made at any time without obligation or notice. Please ensure the local voltage is the same as listed on the specification plate before operating any electric machine.

SAFETY SYMBOLS

The purpose of safety symbols is to attract your attention to possible hazardous conditions



WARNING Indicates a potentially hazardous situation causing injury or death



CAUTION Indicates an alert against unsafe practices.

Note: Used to alert the user to useful information



NOTE:

In order to see the type and model of the machine, please see the specification plate. Usually found on the back of the machine. See example (Fig.1)

Fig.1

HAFCO METALMASTER

PRODUCT SPECIFICATIONS

Model: BG-8	Voltage: 240V/50Hz	
Capacity: 200mm	Motor: 0.75 kW	
Nett Weight: 40kg	FLC: 2.5A	
MFG Date:		

Serial No:

Imported by www.machineryhouse.com.au Made in Taiwan www.machineryhouse.co.nz

CONTENTS

1.1 Specification.....	4
1.2 Accessories Included.....	4
1.3 Identification.....	5
2. SAFETY REQUIREMENTS	
2.1 General Metalworking Machine Safety.....	6
2.2 Specific Safety Grinders.....	9
3. POWER	
3.1 Electrical Installation.....	10
3.2 Full Load Current Rating.....	10
4. SETUP	
4.1 Unpacking.....	11
4.2 Clean Up.....	11
4.3 Lifting Instructions.....	11
4.4 Site Preparation.....	12
4.5 Anchoring To The Floor.....	12
4.6 Assembly.....	13
4.7 Test Run.....	14
5. OPERATION	
5.1 Operation Procedure.....	15
5.2 Changing Wheels.....	16
5.3 Balancing Wheels.....	16
5.4 Troubleshooting.....	17
Spare Parts	
Spare Parts.....	18
Risk Assessment.....	22

1.1 SPECIFICATION

Order Code	K8222
MODEL	BG-8
Grinder Type	Pedestal
Grinding Wheel Diameter (mm)	200
Grinding Wheel Width (mm)	25
Wheel Grade	46 / 60 Grit
Linishing Attachment	Optional
Spindle Shaft Thread Size (Inch)	5/8" 11TPI
Spindle Speed (rpm)	2850
Motor Power (kW / hp)	0.75 / 1
Voltage / Amperage (V / amp)	240 / 10
Dimension (mm)	520 x 3550 x 320
Nett Weight (kg)	40

1.2 ACCESSORIES INCLUDED

- Eye Shields
- Fine and Course Wheels (fitted)
- Stand
- Operation Manual

1.3 IDENTIFICATION

Become familiar with the names and locations of the controls and features shown below to better understand the instructions when mentioned later in this manual.

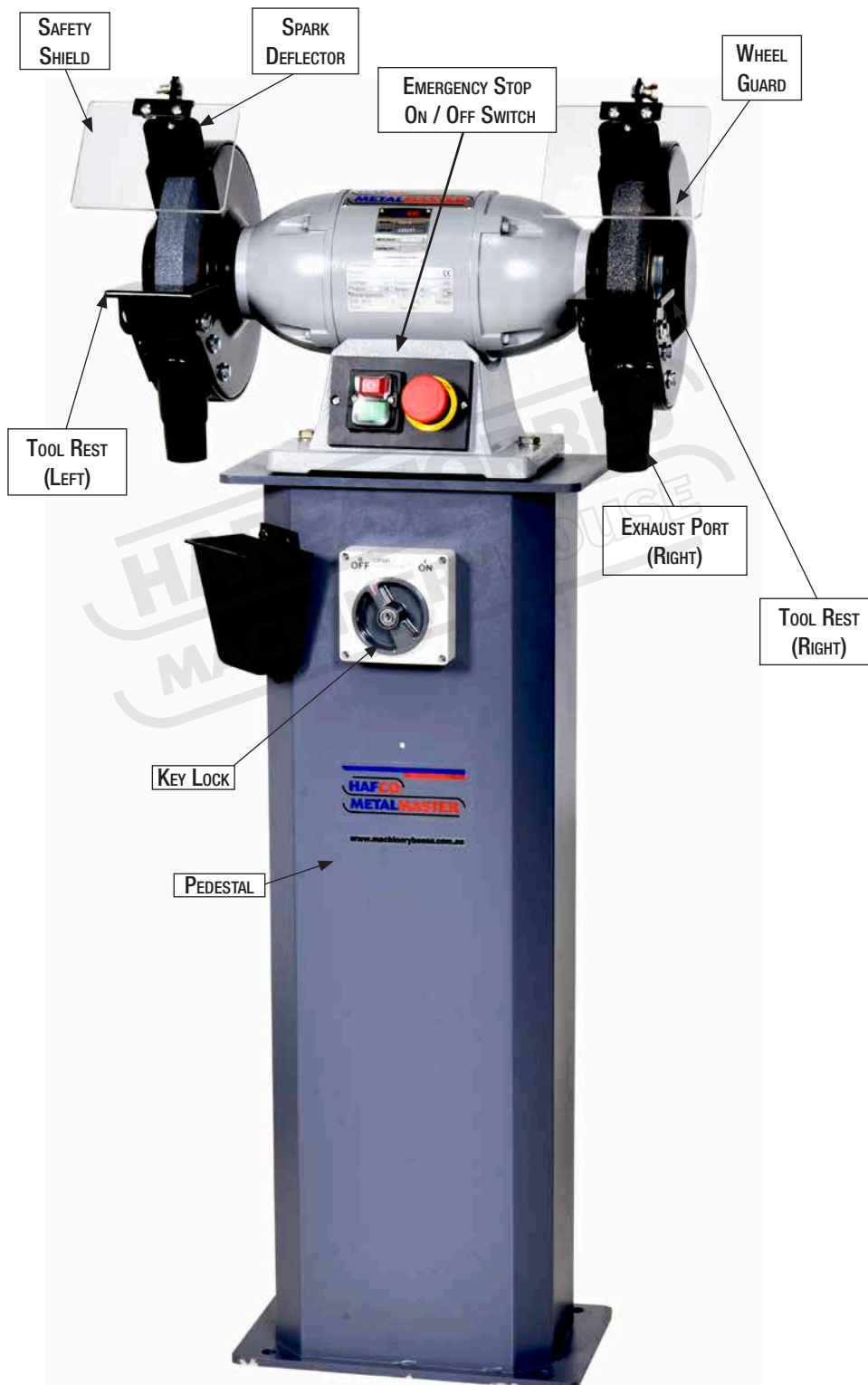

2.1 GENERAL METALWORKING MACHINE SAFETY

DO NOT use this machine unless you have read this manual or have been instructed in the safe use and operation of this machine.



WARNING

This manual provides safety instructions on the proper setup, operation, maintenance, and service of this machine. Save this manual, refer to it often, and use it to instruct other operators. Failure to read, understand and follow the instructions in this manual may result in fire or serious personal injury—including amputation, electrocution, or death.

The owner of this machine is solely responsible for its safe use. This responsibility includes, but is not limited to proper installation in a safe environment, personnel training and authorization to use, proper inspection and maintenance, manual availability and comprehension of the application of the safety devices, integrity, and the use of personal protective equipment.

The manufacturer will not be held liable for injury or property damage from negligence, improper training, machine modifications or misuse.



- ✓ Always wear safety glasses or goggles.
- ✓ Wear appropriate safety footwear.
- ✓ Wear respiratory protection where required.
- ✓ Gloves should never be worn while operating the machine, and only worn when handling the workpiece.
- ✓ Wear hearing protection in areas > 85 dBA. If you have trouble hearing someone speak from one metre (three feet) away, the noise level from the machine may be hazardous.
- ✓ DISCONNECT THE MACHINE FROM POWER when making adjustments or servicing.
- ✓ Check and adjust all safety devices before each job.
- ✓ Ensure that guards are in position and in good working condition before operating.
- ✓ Ensure that all stationary equipment is anchored securely to the floor.
- ✓ Ensure all machines have a start/stop button within easy reach of the operator.
- ✓ Each machine should have only one operator at a time. However, everyone should know how to stop the machine in an emergency.

2.1 GENERAL METALWORKING MACHINE SAFETY Cont.

- ✓ Ensure that keys and adjusting wrenches have been removed from the machine before turning on the power. Appropriate storage for tooling should be provided.
- ✓ Ensure that all cutting tools and blades are clean and sharp. They should be able to cut freely without being forced.
- ✓ Stop the machine before measuring, cleaning or making any adjustments.
- ✓ Wait until the machine has stopped running to clear cuttings with a vacuum, brush or rake.
- ✓ Keep hands away from the cutting head and all moving parts.
- ✓ Avoid awkward operations and hand positions. A sudden slip could cause the hand to move into the cutting tool or blade.
- ✓ Return all portable tooling to their proper storage place after use.
- ✓ Clean all tools after use.
- ✓ Keep work area clean. Floors should be level and have a non-slip surface.
- ✓ Use good lighting so that the work piece, cutting blades, and machine controls can be seen clearly. Position any shade lighting sources so that they do not cause any glare or reflections.
- ✓ Ensure there is enough room around the machine to do the job safely.
- ✓ Obtain first aid immediately for all injuries.
- ✓ Understand that the health and fire hazards can vary from material to material. Make sure all appropriate precautions are taken.
- ✓ Clean machines and the surrounding area when the operation is finished.
- ✓ Use proper lock out procedures when servicing or cleaning the machines or power tools.

DO NOT

- ✗ Do not distract an operator. Horseplay can lead to injuries and should be strictly prohibited.
- ✗ Do not wear loose clothing, gloves, neckties, rings, bracelets or other jewellery that can become entangled in moving parts. Confine long hair.
- ✗ Do not handle cuttings by hand because they are very sharp. Do not free a stalled cutter without turning the power off first. Do not clean hands with cutting fluids.
- ✗ Do not use rags or wear gloves near moving parts of machines.
- ✗ Do not use compressed air to blow debris from machines or to clean dirt from clothes.
- ✗ Do not force the machine. It will do the job safer and better at the rate for which it was designed.



WARNING.

Before operating any machine, take time to read and understand all safety signs and symbols. If not understood seek explanation from your supervisor.

2.1 GENERAL METALWORKING MACHINE SAFETY Cont.

HAZARDS ASSOCIATED WITH MACHINES include, but are not limited to:

- Being struck by ejected parts of the machinery
- Being struck by material ejected from the machinery
- Contact or entanglement with the machinery
- Contact or entanglement with any material in motion

HEALTH HAZARDS (other than physical injury caused by moving parts)

- Chemicals hazards that can irritate, burn, or pass through the skin
- Airborne items that can be inhaled, such as oil mist, metal fumes, solvents, and dust
- Heat, noise, and vibration
- Ionizing or non-ionizing radiation (X-ray, lasers, etc.)
- Biological contamination and waste
- Soft tissue injuries (for example, to the hands, arms, shoulders, back, or neck) resulting from repetitive motion, awkward posture, extended lifting, and pressure grip.

OTHER HAZARDS

- Slips and falls from and around machinery during maintenance
- Unstable equipment that is not secured against falling over
- Safe access to/from machines (access, egress)
- Fire or explosion
- Pressure injection injuries from the release of fluids and gases under high pressure
- Electrical Hazards, such as electrocution from faulty or ungrounded electrical components
- Environment in which the machine is used (in a machine shop, or in a work site)



WARNING!

Machines are safeguarded to protect the operator from injury or death with the placement of guards. Machines must not be operated with the guards removed or damaged.



WARNING!

Abrasive wheels are designed to operate at a maximum speed. Exceeding the speed could cause the wheel or disk to break or de-laminate, resulting in injury or serious eye damage.

2.2 SPECIFIC SAFETY FOR GRINDERS

DO NOT use this machine unless you have read the manual or have been trained and assessed to a competent level in its safe use and operation.



Safety glasses must be worn when operating this equipment



Long and loose hair must be contained when operating this equipment.



Safety footwear must be worn when operating this equipment



Close fitting/protective clothing must be worn when operating the machine



Dust mask must be worn when operating in high dust areas.



Hearing protection must be used when operating in a noisy environment

PRE-OPERATIONAL SAFETY CHECKS

1. Check workspaces and walkways to ensure no slip/ trip hazards are present.
2. Ensure all guards and safety shields (spark deflectors) are in position before starting the grinder.
3. Check that electrical cords are not damaged.
4. Ensure that the grinding wheels are properly 'dressed' and that wheels do not touch the tool rest and that the gap between wheel and rest is no greater than 1.5 mm.
5. Check that grinding wheels are running true (regularly dressed) and are not glazed or loaded.
6. Locate and ensure you are familiar with the operation of the ON/OFF start switch and the Emergency Stop button (where fitted).
7. Faulty equipment must not be used. Immediately report and repair any damaged machinery.

OPERATIONAL SAFETY CHECKS

1. Stand to the side of the wheels when starting up.
2. Let the wheels gain maximum speed before starting to grind.
3. Do not grind on the side of the wheel.
4. Small objects must not be held by hand.
5. Workpiece must never be held with gloves, cloth, apron or pliers.
6. Never leave the machine running unattended.
7. Do not bend down near the machine whilst it is running.
8. Never force the workpiece against a wheel.
9. Slowly move the workpiece across the face of the wheel uniformly. Do not use the side of the grinding wheel to grind workpieces.
10. Coolant spilt on the floor should be immediately cleaned up with an absorbent material.

AFTER OPERATION

1. Switch off the grinder at the end of work and switch off at power point.
2. Check that power leads have not been damaged during use.
3. Clean swarf and leave the machine in a safe, clean and tidy state.

POTENTIAL HAZARDS

- | | |
|--|--|
| 1. Hot metal – use appropriate tools to manage heat. | 2. Sparks – fit spark arresters. |
| 3. Noise – wear approved hearing protection. | 4. Eye injury – wear approved eye PPE. |

3. POWER SUPPLY

3.1 ELECTRICAL INSTALLATION

Place the machine near an existing power source. Make sure all power cords are protected from traffic, material handling, moisture, chemicals, or other hazards. Make sure there is access to a means of disconnecting the power source. The electrical circuit must meet the requirements for 240V.

NOTE : The use of an extension cord is not recommended as it may decrease the life of electrical components on your machine.

ELECTRICAL REQUIREMENTS

Nominal Voltage.....	240V
Cycle.....	50 Hz
Phase.....	Single Phase
Power Supply Circuit.....	10 Amps
Full Load Current.....	2.5 Amps

(Full load current rating is also on the specification plate on the motor.)

3.2 FULL-LOAD CURRENT RATING

The full-load current rating is the amperage a machine draws when running at 100% of the output power. Where machines have more than one motor, the full load current is the amperage drawn by the largest motor or a total of all the motors and electrical devices that might operate at one time during normal operations.

Full-Load Current Rating for these machine at 240V is 2.5 Amps

It should be noted that the full-load current is not the maximum amount of amps that the machine will draw. If the machine is overloaded, it will draw additional amps beyond the full-load rating and if the machine is overloaded for a long period of time, damage, overheating, or fire may be caused to the motor and circuitry.

This is especially true if connected to an undersized circuit or a long extension lead. To reduce the risk of these hazards, avoid overloading the machine during operation and make sure it is connected to a power supply circuit that meets the requirements.



4 SET-UP

4.1 UNPACKING

This machine was carefully packaged for safe transport. When unpacking, separate all enclosed items from packaging materials and inspect them for shipping damage. If items are damaged, please contact your distributor.

NOTE: Save all the packaging materials until you are completely satisfied with the machine and have resolved any issues with the distributor, or the shipping agent.

When unpacking, check the packing list to make sure that all parts shown are included. If any parts are missing or broken, please contact your distributor.

4.2 CLEAN - UP

The unpainted surfaces of the machine have been coated with a waxy oil to protect them from corrosion during shipment. Remove the protective coating with a solvent cleaner or a citrus based degreaser.

Optimum performance from your machine will be achieved when you clean all moving parts or sliding contact surfaces that are coated with rust prevented products.

It is advised to avoid chlorine based solvents, such as acetone or brake parts cleaner, as they will damage painted surfaces and strip metal should they come in contact. Always follow the manufacturer's instructions when using any type of cleaning product.

4.3 LIFTING INSTRUCTIONS



WARNING

This machine is very heavy.

Serious personal injury may occur if safe moving methods are not followed. To be safe, you will need assistance from another person when moving the shipping crate and removing the machine from the crate.



On the day that the machine arrives, make sure that there is assistance, available to unload the machine from the vehicle. Ensure access to the chosen site is clear and that doors and ceilings are sufficiently high and wide enough to receive the machine.



CAUTION

It is impossible to cover all possible hazards Every workshop environment is different. These are designed as a guide to be used to compliment training and as a reminder to users prior to equipment use. Always consider safety first, as it applies to the individual working conditions.

4.4 SITE PREPARATION

When selecting the site for the machine, consider the largest size of workpiece that will be processed through the machine and provide enough space around the machine for operating the machine safely. Consideration should be given to the installation of auxiliary equipment. Leave enough space around the machine to open or remove doors/covers as required for the maintenance and service as described in this manual. It is recommended that the machine is anchored to the floor to prevent tipping or shifting. It also reduces vibration that may occur during operation.

A Safe Working Area must be set around the machine to protect the operator while they work. (See diagram)

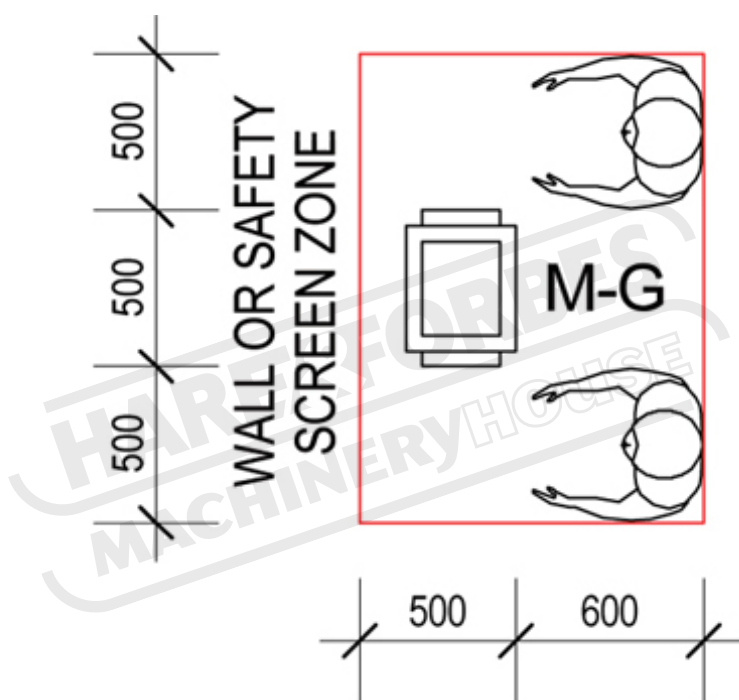

SAFE WORKING AREA

4.5 ANCHORING TO THE FLOOR

The machine is best mounted on a concrete slab. Masonry anchors with bolts are the best way to anchor machinery, because the anchors sit flush with the floor surface, making it easy to unbolt and move the machine later, if needed. (Fig. 4.1)

CAUTION
 Do not install the machine in areas that are wet, cluttered, or have poor lighting.



FIG. 4.1

4.6 ASSEMBLY

The machine must be fully assembled before it can be operated. First clean any parts that are coated in rust preventative to ensure the assembly process can proceed smoothly.

MOUNTING THE GRINDER

The grinder is provided with rubber pads to help prevent movement on a bench or stand. For best results, however, it is recommended the grinder be bolted to the work surface or a grinder stand. (fasteners not included).

1. Align mounting holes on grinder with predrilled holes in a bench or grinder stand.
2. Insert bolts through the holes, and tighten using flat and spring washers and nuts. (Fig. 4.1)

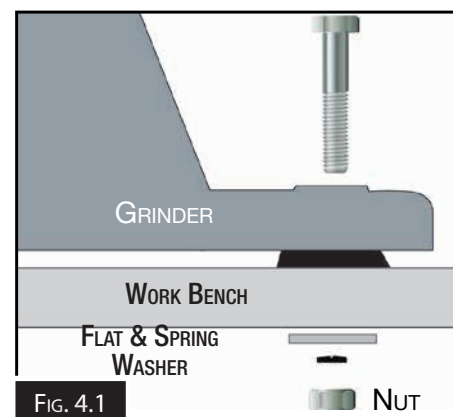

EYE SHIELDS

The eye shields are identical and will fit on either side of the grinder.

1. Insert two pan head screws through the eye shield bracket (B), eye shield, and eye shield plate (A) which contains and secure with a flat washer and nut.
2. Tighten the screws and nuts.

Note: Spark deflectors (D) and Brackets (C) are marked for left side assembly and for right side assembly.

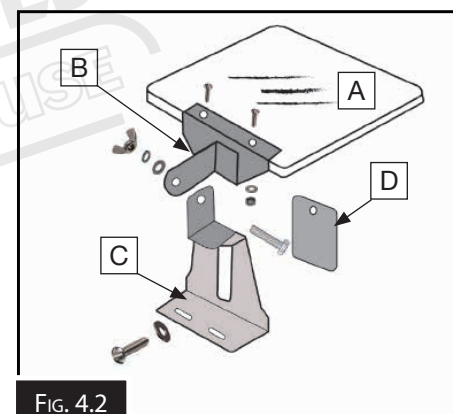

3. Assemble the left spark deflector(D) and eye shield bracket (C) using Fig. 4.2 as a guide. Make sure spark deflector and bracket are marked L.
4. Install the right assembly in the same manner.

TOOL RESTS

1. Install the right tool rest bracket (F) by threading two hex head screws and two flat washers and through the tool rest bracket (F) and into the wheel housing. (Fig. 4.3)
2. Place the tool rest (E) over the bracket (F) and secure with bolts supplied, making sure that there is only a 2 mm gap between the wheel and the tool rest.
3. Install the left tool rest in the same manner.

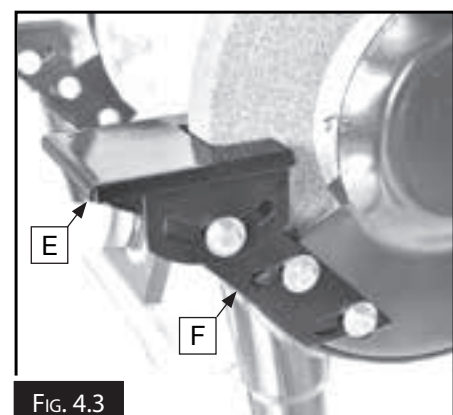

4.7 TEST RUN

Once assembly is complete, test run the machine to ensure it is properly connected to the power and safety components are functioning correctly. Check that the direction of the motor is correct and make sure that the machine rotates in the correct direction.

If the direction is incorrect, isolate the machine and have the electrician make changes to the wiring. If you find an unusual problem during the test run, immediately stop the machine, disconnect it from power, and fix the problem BEFORE operating the machine again. The Troubleshooting table in the Maintenance section of this manual may be able to help. If the problem persists then contact your dealers service technician.

To test run the machine:

1. Connect the machine to the power supply.
2. Make sure that the manual has been read and that the safety instructions at the beginning of the manual are understood. Make sure the machine has been setup correctly
3. Make sure all tools and objects used during set up have been cleared away from the machine.
4. Turn the machine ON.
5. Make sure that the motor is travelling in the correct direction.
6. Listen to and watch for abnormal noises or actions. The machine should run smoothly with little or no vibration or rubbing noises.
7. Any strange or unusual noises should be investigated and corrected before operating the machine again. Always disconnect the machine from power supply when investigating or correcting potential problems. The troubleshooting chart in the maintenance section may be helpful in rectifying a problem.

TESTING THE EMERGENCY STOP BUTTON

Make sure that the emergency button is working correctly

1. Twist the top of the Emergency Stop button to ensure that it is in the raised position.
2. Start the machine and then press the emergency stop button. The machine should stop and the power should be cut off. If the machine cannot be started then the emergency stop is working correctly.
3. To reset the Emergency Stop twist the red top until it pops up. The machine should now work again.



5. OPERATION

A bench grinder is designed for hand-grinding operations such as sharpening chisels, screwdrivers, drill bits, removing excess metal, and smoothing metal surfaces.

A Medium Grain Abrasive Grinding Wheel is suitable for rough grinding where a considerable amount of metal must be removed or when obtaining a smooth finish is not important.

A Fine Grain Abrasive Grinding Wheel should be used for sharpening tools to close size tolerances because it removes metal more gradually for precision grinding and gives work a smooth finish.

5.1 OPERATIONAL OVERVIEW

The purpose of this overview is to provide the novice machine operator with a basic understanding of how the machine is used during operation, so the machine controls and components discussed later in this manual are easier to understand.

TYPICAL OPERATION,

1. Examine the workpiece to ensure that it is suitable for grinding.
2. Select the correct grinding wheel for type of workpiece grinding. If replacing the grinding wheel inspect the wheel, and perform a "ring test," before installing the new wheel.
3. Check the tool rest position so it is square to the grinding wheel and the gap is 2mm to 3mm. Adjusts spark deflector and wheel gap to 2-3mm.
4. Adjusts the safety shield for safe grinding.
5. Ensures that ON/OFF switch is in OFF position, and connects grinder to power.
6. Personal protective eyewear and clothing must be worn.
7. Stand to one side when starting the grinder, and allow the wheel to reach full speed and operate for at least 1 minute to ensure wheel does not fly apart from the centrifugal force of rotation.
8. Place workpiece on the tool rest and position it for grinding.
9. Gradually feed the workpiece into the grinding wheel and move the workpiece left and right to prevent grooves in wheel.
10. Quenche the workpiece as required to prevent surface hardening or temper loss.
11. Stop the bench grinder when finished.



WARNING.

Abrasive sparks from grinding can cause serious and permanent eye damage. Always use a face shield and safety glasses together to insure best eye protection.

5.2 CHANGING WHEELS

If you must replace a wheel be sure to obtain one with a safe rated speed at least as high as the NO LOAD RPM marked on the grinder's nameplate. See table below for wheel dimensions.

	WHEEL DIAMETER	MAXIMUM WIDTH	CENTRE BORE
BG-8	200MM	25MM	5/8"

1. DISCONNECT THE MACHINE FROM THE POWER SUPPLY.
2. Undo the bolts that secure the toolrest, eyeshield and dust chute from the wheel cover, and remove them.
3. Remove the screws around the wheel cover and remove the cover.
4. Remove the nut, disc washer or balancing flange and the old wheel.
5. Place the new wheel and parts back in reverse order.

NOTE! It's important to balance the wheel before replacing the wheel covers. Check all the screws and bolts. Make sure they are all tightened before switching on the Grinder.

6. Check the distance between the wheel, the spark deflector and the toolrest table. It should always remain at about 2~3mm to get the better spark deflecting effect and safe grinding performance. When this distance is changed due to the wearing of the wheel, then adjustment needs to be made.

5.3 WHEEL BALANCING

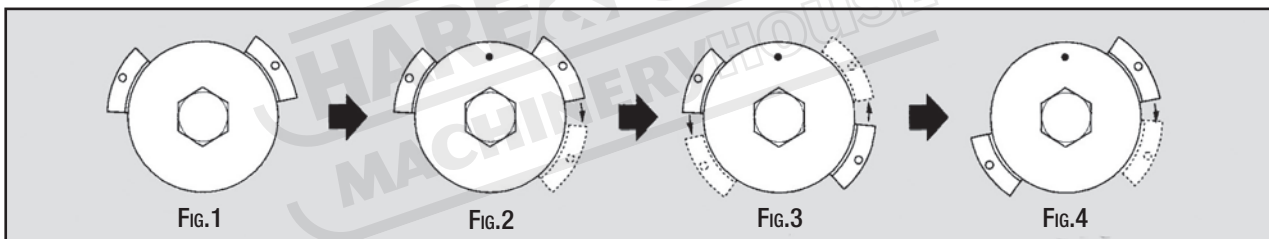

The balancing adjustment is achieved through balancing blocks on the balancing flange. It requires repeated testing by moving the position of the two balancing blocks until the wheel is balanced.

HOW TO BALANCE THE WHEEL.

1. Check that the new wheel has been installed correctly and the wheel nuts have been tightened.
2. Place two balancing blocks in the position shown in figure 1. Start the grinder and check the balancing result.
3. If the wheel is not balanced, switch off the grinder and after the wheel has stopped turning, move the wheel by hand to the original position as in figure 1. Mark the position of the blocks on the wheel with a piece of chalk.
Move the right hand balancing block clockwise to new position, as in figure 2. and tighten it. Make the second test run and check again.
4. Switch off if still not satisfied. Return the balancing blocks to original position, then move the left hand balancing block counterclockwise to new position as in figure 3. and make the test run again.
5. If the wheel is still not balanced, stop the machine and move the balancing blocks to the position as in figure 4.

NOTE! Adjustment to the balancing blocks should be done as per the steps mentioned above, as it will make it easy to understand the characteristics of the changes.

5.4 TROUBLESHOOTING

Review the troubleshooting and procedures in this section if a problem develops with your machine. If you need replacement parts then follow the procedure in the beginning of the spare parts section or if additional help with a procedure is required, then contact your distributor.

Note: Make sure you have the model of the machine, serial number, and manufacture date before calling.

Symptoms	Possible Cause	Possible Solution
Motor will not start	Not plugged into receptacle.	Plug must be fully inserted into receptacle.
	Switch not in ON position.	Make sure switch is moved completely to ON position.
	Motor cord cut or abraded.	Replace with new cord.
	Plug on cord is faulty.	Replace with new plug.
	Fuse blown or circuit breaker tripped.	Re-set. (There may be too many machines on circuit.)
	Motor faulty	Contact Hafco/Metalmaster Service Centre
Motor will not start and fuse blows or circuit breaker trips	Too many machines running on same electrical circuit.	Turn off other machines and try again.
	Incorrect fuse.	Try time delay fuse, or go to circuit with higher rated fuse or circuit breaker.
	Wheels cannot rotate because of obstruction.	Unplug and turn grinding wheel by hand; clear any obstructions.
	Undersized extension cord.	Use correct size extension cord.
	Short circuit.	Cord, plug, or motor needs repair; contact Hafco Service.
Motor fails to develop full power.	Low line voltage.	Have an electrician check power line for proper voltage.
	Faulty motor or capacitor.	Contact Hafco/Metalmaster Service Centre
Motor overheats	Overload on motor.	Reduce load on motor; do not press so hard.
	Capacitor failure.	Contact Hafco/Metalmaster Service Centre.
Motor stalls or slows	Motor overload.	Reduce load on motor; do not press so hard.
	Low line voltage.	Check power line for proper voltage.
	Loose wire connections.	Contact Hafco/Metalmaster Service Centre.
	Faulty motor.	Contact Hafco/Metalmaster Service Centre..
Frequent fuse or circuit breaker failure.	Motor overload.	Reduce load on motor; do not press so hard.
	Overload of electrical circuit.	Too many electrical appliances on same circuit.
	Incorrect fuse or circuit breaker.	Have electrician upgrade service to outlet.
Grinding wheels won't spin true	Arbor nut too tight, springing the flanges.	Do not overtighten nut.
	Flange(s) warped, or flange surface is not flat.	Replace flange(s).
	Wheel bushings have too much play.	Install new bushings or replace wheel.
	Arbor damaged.	Contact Hafco/Metalmaster Service Centre.
Excessive vibration	Incorrect size or type of wheel.	Match wheel size to grinder specifications. Use proper wheel type for job being done.
	Wheels out of balance.	Balance wheels. See page 16
	Too much play in wheel bushing.	Install new bushings or replace wheel.
	Flanges are worn, bent or have burrs.	Inspect flanges, replace if needed.
	Worn bearings in grinder.	Replace bearings. Contact Hafco/Metalmaster Service Centre.
	Poor quality wheel.	Replace wheel with one of better quality.



WARNING

Always disconnect the power to the machine before servicing or doing maintenance to the machine.

SPARE PARTS SECTION

INDUSTRIAL PEDESTAL GRINDER

Model. BG-8

Order Code K8222

EDITION No : BG-8-1
DATE OF ISSUE : 08/2023

The following section covers the spare parts diagrams and lists that were current at the time this manual was originally printed. Due to continuous improvements of the machine, changes may be made at any time without notification.

HOW TO ORDER SPARE PARTS

1. Have your machines model number, serial number & date of manufacture on hand, these can be found on the specification plate mounted on the machine
2. A scanned copy of your parts list/diagram with required spare part/s identified.

NOTE: SOME PARTS MAY ONLY BE AVAILABLE AS AN ASSEMBLY

3. Go to www.machineryhouse.com.au/contactus and fill out the inquiry form attaching a copy of scanned parts list.



WARNING

***Disconnect all power from the machine before servicing.
There may be multiple power sources present.
Remove the plug from the power point or remove the
fuse if hardwired. Failure to do may cause death or injury.***

240 VOLT SPARE PARTS DIAGRAM

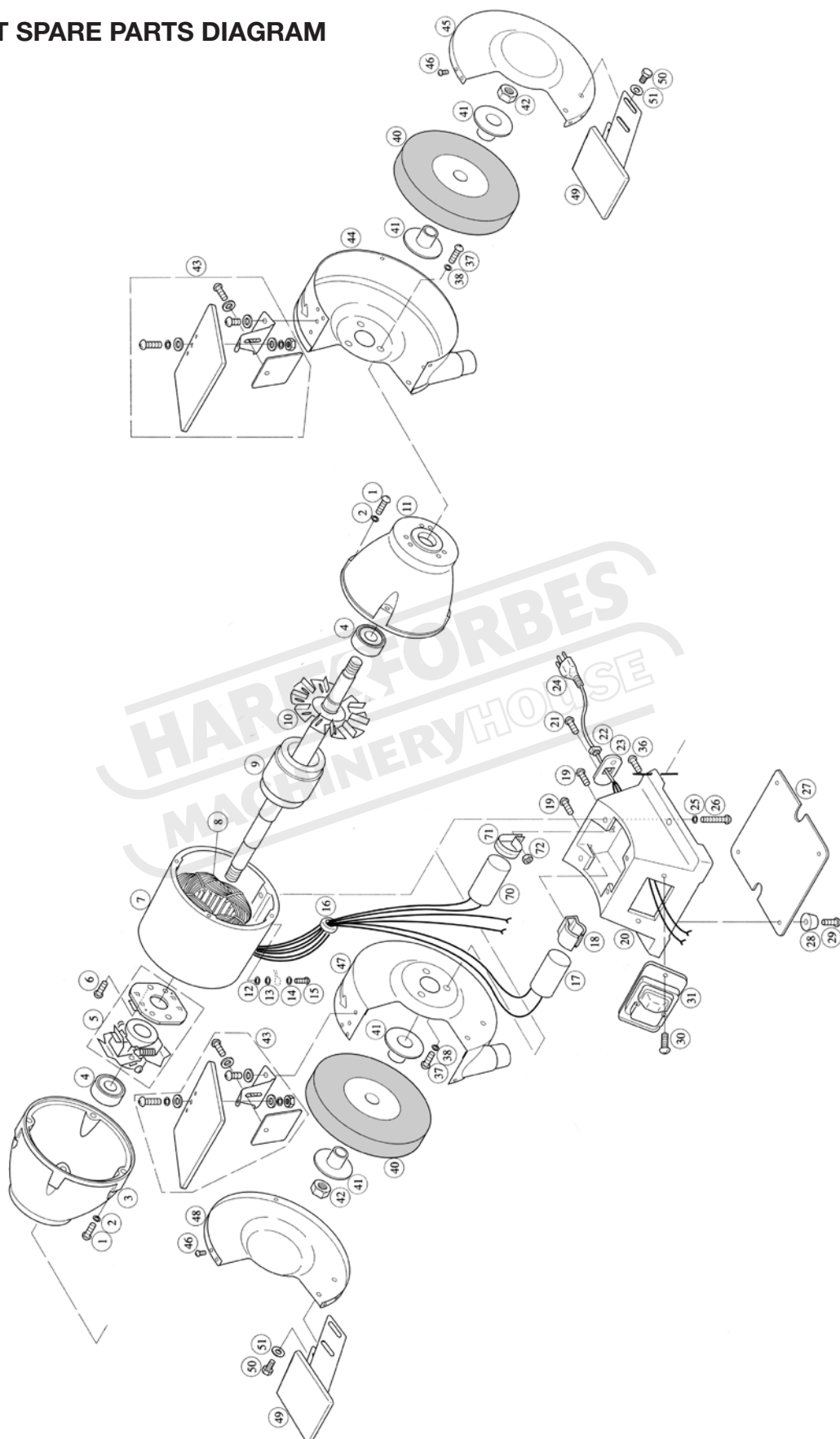

PG-8 SPARE PARTS LISTS

1. Cap Screw	40. Grinding Wheel
2. Spring Washer	41. Sleeve
3. Left Support	42. Hex. Nut
4. Ball Bearing	43. Eyeshield Set
5. Centrifugal Switch # (10" Grinder Only)	44. Right Int. Cover A
6. Screw	45. Right Wheel Cover A
7. Stator Housing	46. Screw
8. Stator	47. Left Int. Cover A
9. Rotor Shaft	48. Left Wheel Cover A
10. Fan	49. Toolrest
11. Right Support	50. Hex. Bolt
12. Ext. Washer	51. Washer
13. Copper Set	
14. Int. Washer	
15. Screw	
16. Grommet Rubber	
17. Running Capacitor	
18. Clamp	
19. Screw	
20. Grinding Base	
21. Screw	
22. Cable Strainer	
23. Fixing Plate	
24. Power Cord	
25. Washer	
26. Hex Bolt	
27. Base Plate	
28. Pad	
29. Screw	
30. Screw	
31. NVR	
36. Screw	
37. Screw	
38. Spring Washer	

NOTE: SOME INDIVIDUAL PARTS MAY ONLY BE AVAILABLE AS AN ASSEMBLY